

PASSO 1/STEP 1

MODIFICA FORO DI PASSAGGIO
FLOW HOLE MODIFY

N° 1 FORO 2,5 mm NON PASSANTE
N° 1 HOLE 2,5 mm NOT ALL THROUGH

Dimensions in mm

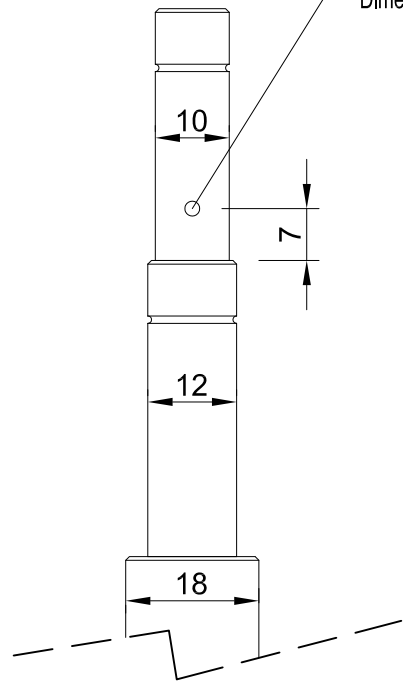

PASSO 2/STEP 2

ATTENZIONE!! ATTENTION!!

ADATTARE POSIZIONE 2° PISTONE UTILIZZANDO RONDELLE
E LAMELLE DATE IN DOTAZIONE
ADAPT 2° PISTON POSITION USING WASHERS OR SHIMS
DELIVERED WITH THE KIT

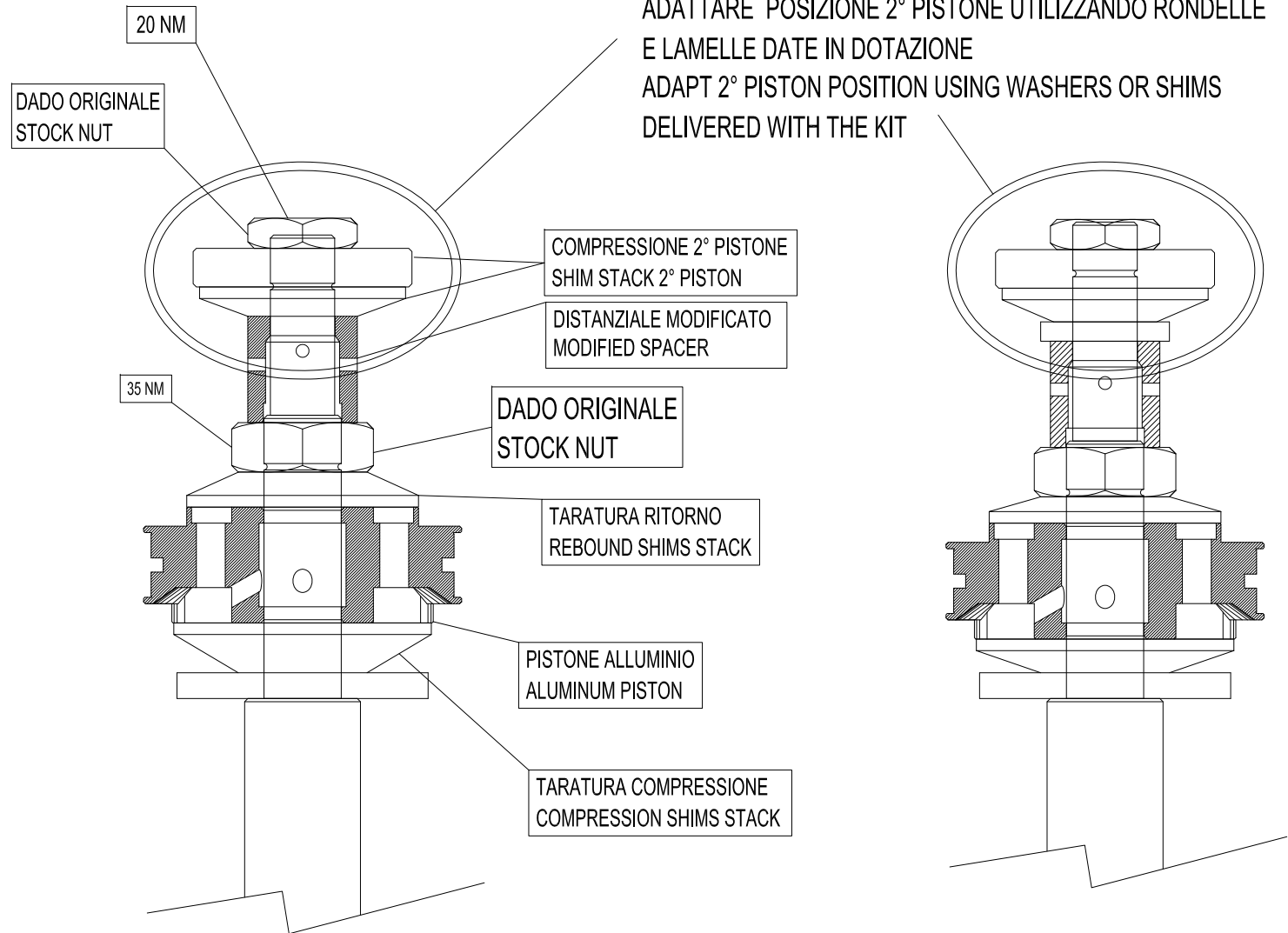

Project: KIT Pistone Mono WP Xplor Full upgrade LAINER

Lainer Suspension Racing - Via Ventinove 4 - 48125 Ravenna
www.lainersuspension.com info@lainersuspension.com T. 347 4685185